

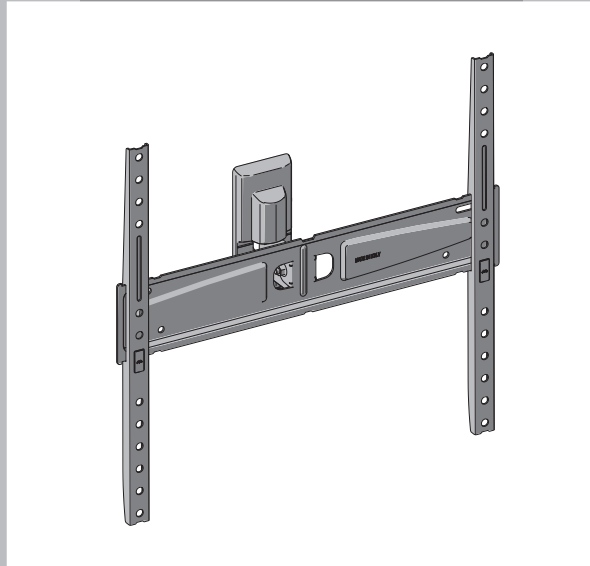

# FLATSTYLE FTR400



IT ISTRUZIONI DI MONTAGGIO  
FR INSTRUCTIONS DE MONTAGE  
EN MOUNTING INSTRUCTIONS  
DE MONTAGEANLEITUNG  
NL MONTAGEVOORSCHRIFT  
ES GUÍA DE MONTAJE  
PT INSTRUÇÕES DE MONTAGEM  
PL INSTRUKCJA MONTAŻU  
CZ NÁVOD K MONTÁŽI  
RO INSTRUCȚIUNI DE MONTARE  
HU SZERELÉSI ÚTMUTATÓ  
FI ASENNUSOHJEET  
SK NÁVOD NA MONTÁŽ  
SL NAVODILA ZA MONTAŽO  
MK ИНСТРУКЦИЈА ЗА МОНТАЖА  
SQ UDHËZIME PËR MONTIMIN

Meliconi S.p.A. - V. Minghetti, 10  
40057 Cadrano di Granarolo E. (BO) Italy  
www.meliconi.com e-mail: info@meliconi.com



**IT** Attrezzatura per montaggio **FR** Outils d'assemblage **EN** Assembly equipment **ES** Herramientas de montaje

**IT** Dati tecnici **FR** Caractéristiques techniques **EN** Technical data **ES** Datos técnicos

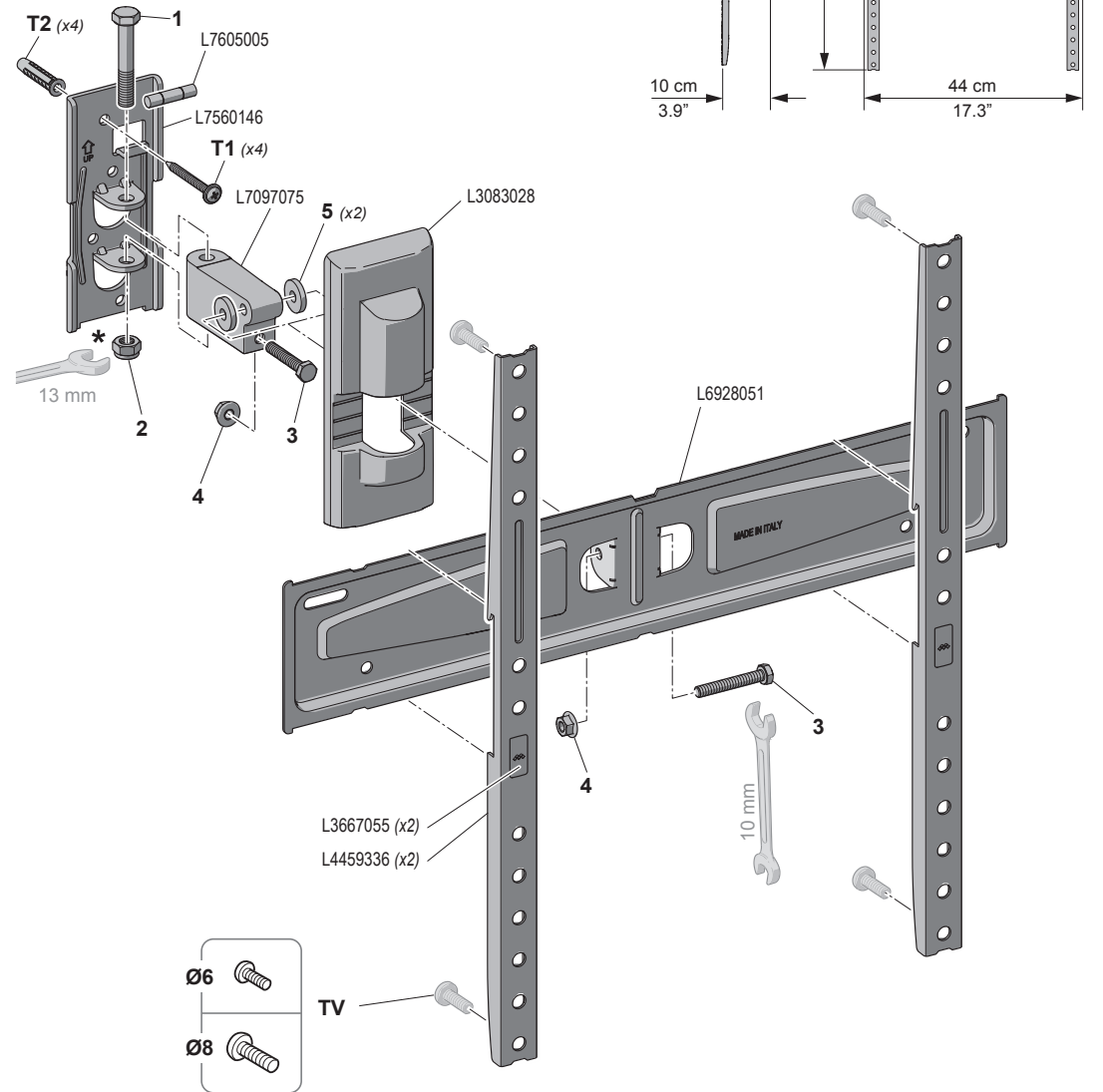

**\*** **IT** Dado autobloccante, specifico per evitare svitamenti accidentali. Avvitare in maniera decisa, con gli appositi attrezzi, anche dopo aver avvertito la prima resistenza.  
**FR** Écrou autobloquant, conçu pour éviter tout desserrage accidentel. Serrez fermement, avec les outils appropriés, même après avoir perçu la première résistance.  
**EN** Self-locking nut, designed to prevent accidental loosening. Tighten firmly, with the correct tools, even after feeling the first resistance.  
**ES** Tuerca autobloqueante para evitar que se afloje. Enroscar a fondo con las herramientas específicas, incluso después de haber notado la resistencia inicial.

**1:1** 0 mm 10 20 30 40 50 60 70

**T2 (x4)** Ø8 L4468138

**T1 (x4)** Ø5 x 50 L4468138

**TV (x4)** Ø8 x 15 L4459513

**TV (x4)** Ø6 x 15 L4459513

**TV (x4)** Ø8 x 20 L7950137

**TV (x4)** Ø6 x 16 L7950244

**3 (x2)** Ø6 x 40 L7950286

**1** Ø8 x 50 L7950350

**5 (x2)** Ø18 x 6,4 x 3 L6313036

**2** Ø8 L3602024 \*

**4 (x2)** Ø6 L3602019

